

Specifications

Nominal Voltage (V)		12	
Nominal Capacity (AH)		200	
Dimensions	Length	522 mm	20.55 inch
	Width	238 mm	9.37 inch
	Height	218 mm	8.58 inch
	Total Height	223 mm	8.78 inch
Approx. Weight		73.4 kgs	161.82 lbs
Standard Terminals		V8	
Case Material		ABS UL 94-HB	

Characteristics

Capacity	100 hour rate	2.20 A	220.0 Ah
	20 hour rate	10.00 A	200.0 Ah
	10 hour rate	19.60 A	196.0 Ah
	5 hour rate	30.00 A	150.0 Ah
	1 hour rate	110.0 A	110.0 Ah
Internal Resistance		3.05m Ω	
Max. Discharge Current (5 sec)		4645 A	
Constant Voltage Charge Method	Max. Charge Current	40 A	
	Standby Use	2.23 - 2.27 V /Cell	
	Cycle Use	2.33 - 2.37 V /Cell	
Operating Temperature Range	Discharge:	-20 ~ 55 °C (-4 ~ 131°F)	
	Charge:	-10 ~ 55 °C (14 ~ 131°F)	
	Storage:	-20 ~ 55 °C (-4 ~ 131°F)	
Temperature coefficient	For standby use:	-3.0mV / °C /Cell	
	For cycle use:	-3.3mV / °C /Cell	
Self discharge 25°C (77°F)	After 3-month	94%	
	After 6-month	88%	
	After 12-month	76%	
Temperature dependency of Capacity	40 °C (104 °F)	104%	
	25 °C (77 °F)	100%	
	0 °C (32 °F)	85%	
	-20 °C (5 °F)	65%	

Capacity with Different Temperature

Temperature	-20°C	-10°C	0°C	25°C	40°C
Capacity	60%	75%	85%	100%	104%

Dimensions

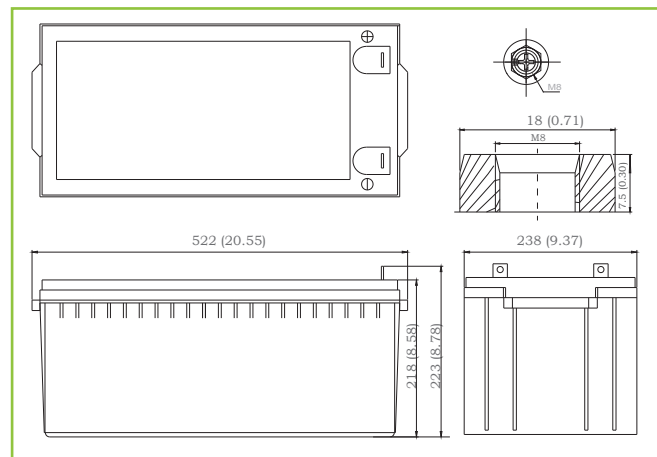

LVJ 200-12



LVJ 200-12 VRLA (valve-regulated lead acid) GEL battery is designed with 12 years float life at 25°C for wide ranging applications. With superfluous electrolyte evenly distributed in a special PVC-SiO₂ separator and a patented grid design, this battery is perfect for cyclic use, and has a greater ability to withstand heat and deep discharge. Recommended for use with photovoltaic and wind power systems. LiveN is ISO9001 and UL certified for quality assurance.



Terminal Voltage (V) and Discharge Time

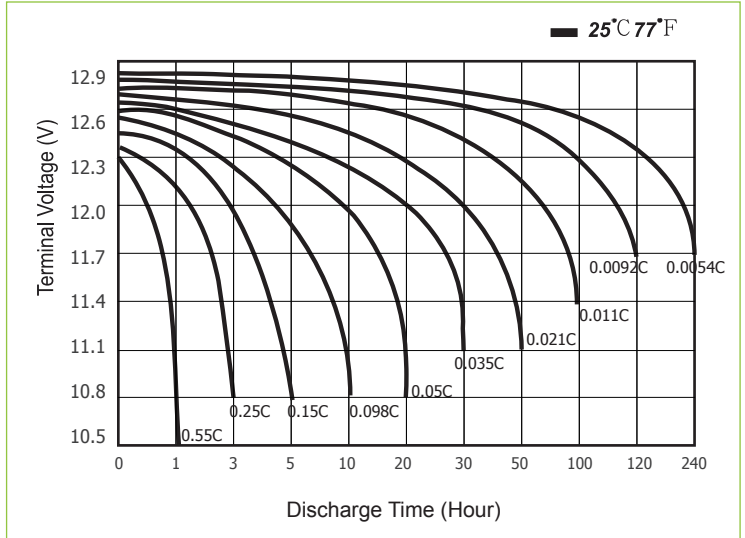

Battery Voltage and Charge Time for Standby Use

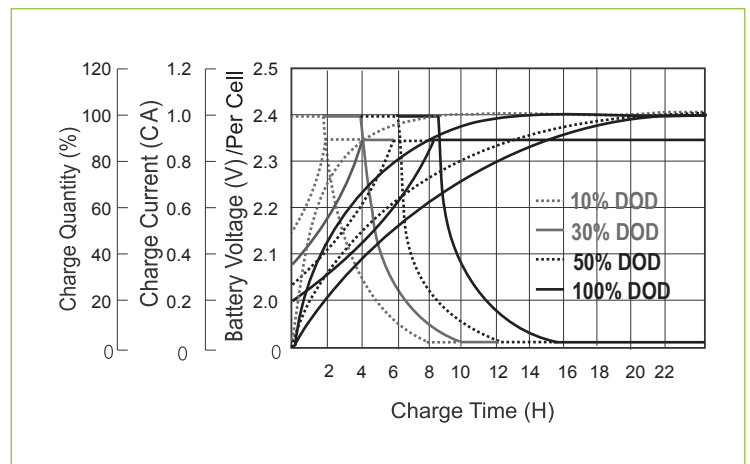

Cycle Service Life

