

Powered by



# HR 12120W ▶ 12V 120W

HR 12120W is specially designed for high efficient discharge application. Its characteristics are high energy density, small footprint and high discharge efficiency. It can be used for more than 260 cycles at 100% discharge in cycle service, up to 5 years in standby service.



## Specification

Cells Per Unit	6
Voltage Per Unit	12
Capacity	120 W @ 15min-rate to 1.67V per cell @25 °C (77°F)
Weight	Approx. 10.2 kg(22.49 lbs)
Maximum Discharge Current	400A(5sec)
Internal Resistance	Approx. 9 m Ω
Operating Temperature Range	Discharge: -15°C~50°C ( 5°F~122°F) Charge: -15 °C~40°C ( 5°F~104°F) Storage: -15°C~40°C ( 5°F~104°F)
Nominal Operating Temperature Range	25°C±3°C(77°F±5°F)
Float Charging Voltage	13.5 to 13.8 VDC/unit Average at 25°C (77°F)
Recommended Maximum Charging Current Limit	12A
Equalization and Cycle Service	14.4 to 15.0 VDC/unit Average at 25°C (77°F)
Self Discharge	CSB Batteries can be stored for more than 6 months at 25°C (77°F). Please charge batteries before using. For higher temperatures the time interval will be shorter.
Terminal	I1-Thread lead alloy recessed terminal to accept M5 bolt
Container Material	ABS(UL 94-HB/File E50263)*Flammability resistance of (UL 94-V0/File E88637) can be available upon request.



MH14533(N)



CSB-manufactured VRLA batteries are UL-recognized components under UL924 and UL1989.

CSB is also certified by ISO 9001 and ISO 14001.

Dimensions :	Overall Height (H)	Container height (h)	Length (L)	Width (W)
Unit: mm (inch)	175±2 (6.89±0.08)	166.5±2 (6.55±0.08)	166±2 (6.53±0.08)	125±1.5 (4.92±0.06)

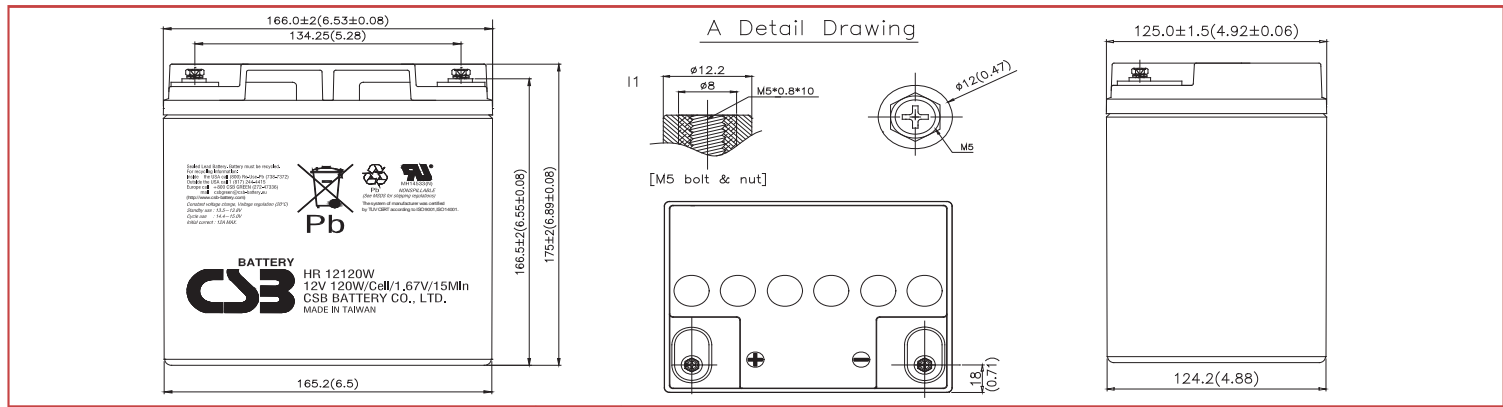

## Constant Current Discharge Characteristics Unit:A (25°C ,77°F)

F.V/Time	2MIN	4MIN	6MIN	8MIN	10MIN	15MIN	20MIN	30MIN	60MIN	90MIN
1.60V	169	148	125	107	94.2	70.5	56.1	41.2	24.5	16.8
1.67V	153	135	115	100	88.9	67.0	53.6	39.7	24.0	16.6
1.70V	146	128	109	95.5	85.6	65.3	52.5	39.2	23.7	16.4
1.75V	132	117	101	88.9	80.2	62.0	50.4	37.8	23.1	16.2
1.80V	117	105	91.2	81.3	73.3	58.3	48.0	36.0	22.2	15.8
1.85V	100	92.5	82.4	74.3	67.3	54.3	45.7	34.6	21.2	15.2

## Constant Power Discharge Characteristics Unit:W (25°C ,77°F)

F.V/Time	2MIN	4MIN	6MIN	8MIN	10MIN	15MIN	20MIN	30MIN	60MIN	90MIN
1.60V	1,745	1,622	1,419	1,199	1,030	771	621	462	284	197
1.67V	1,608	1,495	1,315	1,119	975	738	600	453	279	194
1.70V	1,539	1,427	1,260	1,084	947	724	590	447	276	193
1.75V	1,412	1,306	1,161	1,012	895	701	578	435	270	190
1.80V	1,273	1,181	1,060	944	853	676	561	418	263	186
1.85V	1,100	1,045	966	877	805	648	536	402	253	181

### Trickle (or Float) Service Life

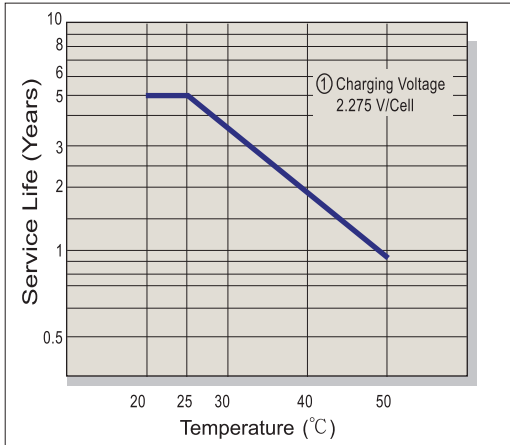

### Capacity Retention Characteristic

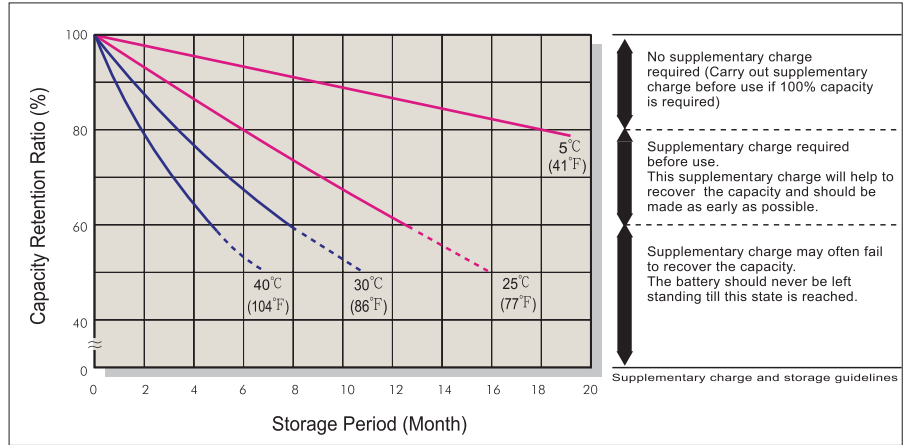

### Battery Voltage and Charge Time for Standby Use

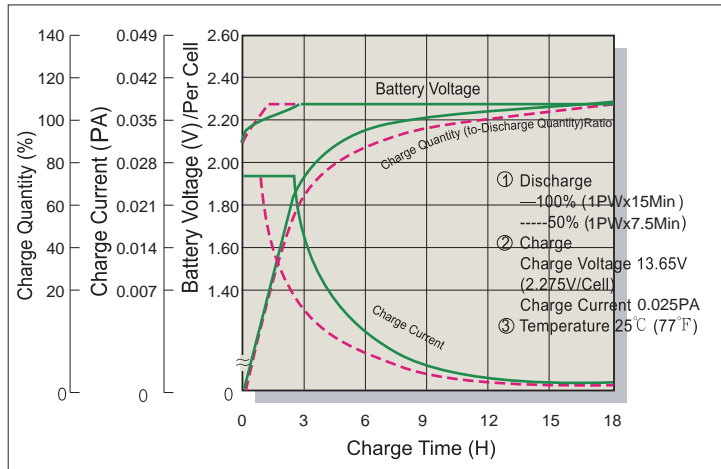

### Cycle Service Life

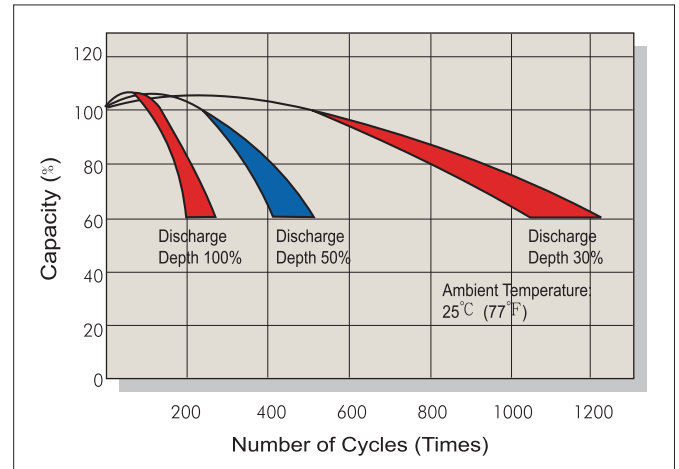

### Battery Voltage and Charge Time for Cycle Use

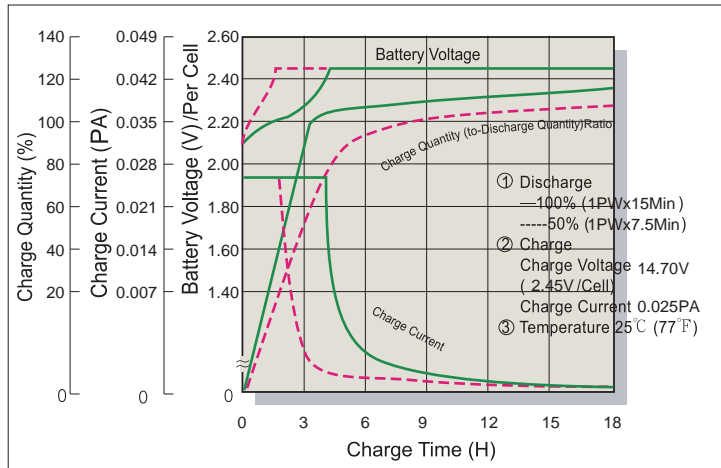

### Terminal Voltage (V) and Discharge Time

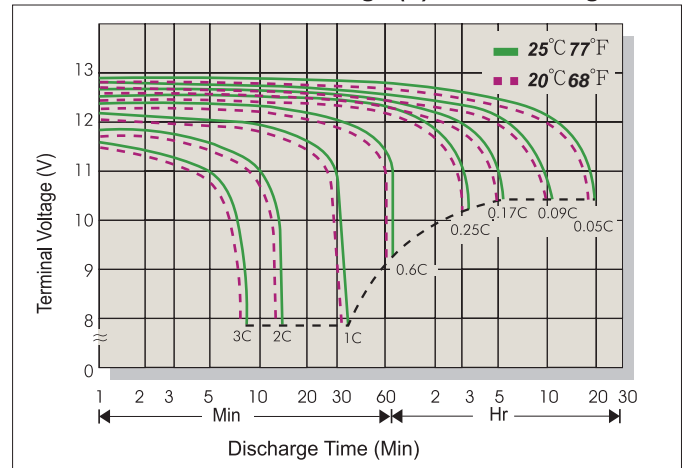

### Charging Procedures

Application	Charge Voltage(V/Cell)			Max.Charge Current
	Temperature	Set Point	Allowable Range	
Cycle Use	25°C(77°F)	2.45	2.40-2.50	0.3C
Standby	25°C(77°F)	2.275	2.25-2.30	

### Discharge Current VS. Discharge Voltage

Final Discharge Voltage V/Cell	1.75	1.70	1.60	1.30
Discharge Current(A)	0.2C>(A)	0.2C<(A)<0.5C	0.5C<(A)<1.0C	(A)>1.0C

Sales Office URL: [WWW.CSB-BATTERY.COM](http://WWW.CSB-BATTERY.COM)

**GLOBAL HQ**  
 CSB BATTERY CO., LTD. (TAIWAN)  
 Tel : +886-2-2555-5600  
 Fax : +886-2-2555-3300  
 mail : service@csb-battery.com.tw

**BEIJING OFFICE. (CHINA)**  
 CSB BATTERY TECHNOLOGIES (BEIJING) CO., LTD.  
 Tel : +86-10-59621300/1301/1302/1303  
 Fax : +86-10-59621304  
 mail : chinasl@csb-battery.com

**AMERICA HQ**  
 CSB BATTERY TECHNOLOGIES INC. (U.S.A)  
 Tel : +1-817-244-7777/1-(800)3-CSB-USA(272872)  
 Fax : +1-817-244-4445  
 mail : csb@csb-battery.com

**SHANGHAI OFFICE. (CHINA)**  
 CSB BATTERY LOGISTIC (SHANGHAI) CO., LTD.  
 Tel : +86-21-5046-1622/5046-0833  
 Fax : +86-21-5064-3314  
 mail : chinasl@csb-battery.com

**EUROPE HQ**  
 CSB Battery Europe BV.  
 Tel : +31(0)-180-418-140  
 Fax : +31(0)-180-418-327  
 mail : eurosales@csb-battery.eu

**SHENZHEN OFFICE. (CHINA)**  
 CSB BATTERY LOGISTIC (SHANGHAI) CO., LTD.  
 Tel : +86-755-8831-6488/6396/6356  
 Fax : +86-755-8831-6548  
 mail : she@csb-battery.com.cn